

Slurry Champ

100XP

**HEAVY DUTY HYDRAULIC
SUBMERSIBLE SLURRY PUMP**

FOR EXCAVATOR

NUMBER ONE FOR RELIABILITY, STRENGTH & ENDURANCE

TECHNICAL DATA SHEET

100XP

HEAVY DUTY HYDRAULIC SUBMERSIBLE SLURRY PUMP

FOR EXCAVATOR



Standard Engineering Features

- Single piece cast iron body to enhance rigidity and reduce wear
- Bearings run in oil bath for lubrication and cooling
- Twin volute casing design to reduce rotational imbalance and increase lifetime of bearings and seals
- Rotating inducer creates hydrodynamic shock waves to re-suspend settled particles beneath the pump inlet
- Single stage, open vane impeller
- Precision bearings
- Non pressurised mechanical seal
- Bent axis swash plate piston motor without case drain.

MINE TAILINGS
RIVER AND POND DREDGING
COAL ASH SLURRY
SAND AND SILT
MUD PUMPING
SLUDGE AND WASTE SLURRY

Pump Data

Design fluid handled	Slurry
Maximum fluid SG	2.0 kg/l
Maximum fluid solids content	55 % by weight
Maximum particle size	32 mm
Maximum fluid temperature	90 °C
Recommended pH range	4-10
Weight	525 kg
Outlet diameter	100 mm
Maximum flow	230 m ³ /hr @ 1500rpm
Maximum head	51 m (5.0 bar) @ 1800rpm
Impeller diameter	320 mm
Impeller tip speed	24 m/s @ 1800rpm
Peak efficiency	62 %
Maximum submergence depth*	28 m
Motor displacement	63cc
Speed range	1200 - 1800rpm

*As standard, can be deeper if required.

Other Data

Hydraulic service live ports	SAE J518 Code 62 3/4 inch (6000psi)		
Allowable hydraulic pressure	250 bar		
Hydraulic service drain port	3/4 inch - 16UNF-2B		
Required hydraulic oil supply	RPM	Water	Slurry SG 2.0 Kg/l
	1200rpm	73 Litres per minute @ 65 bar	73 Litres per minute @ 130 bar
	1500rpm	93 Litres per minute @ 98 bar	93 Litres per minute @ 196 bar
	1800rpm	108 Litres per minute @ 125 bar	108 Litres per minute @ 250 bar

Slurry Champ

Dimensions

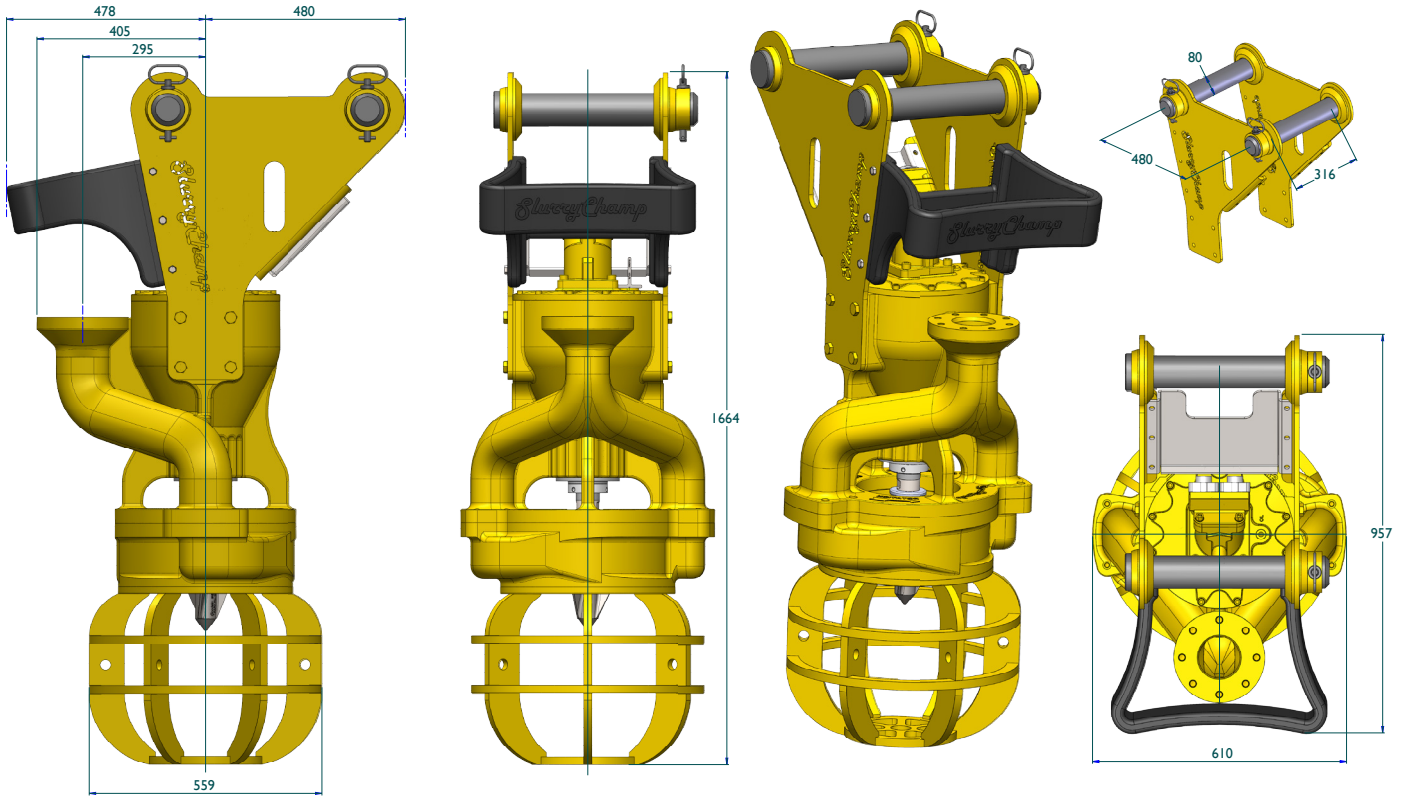

Note: Alternative lifting pin configuration are available to suit excavators.

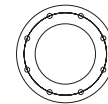

(Fits 100mm PN16)
M16*2.0P- 8 Places
ø179mm PCD

Pump Curve

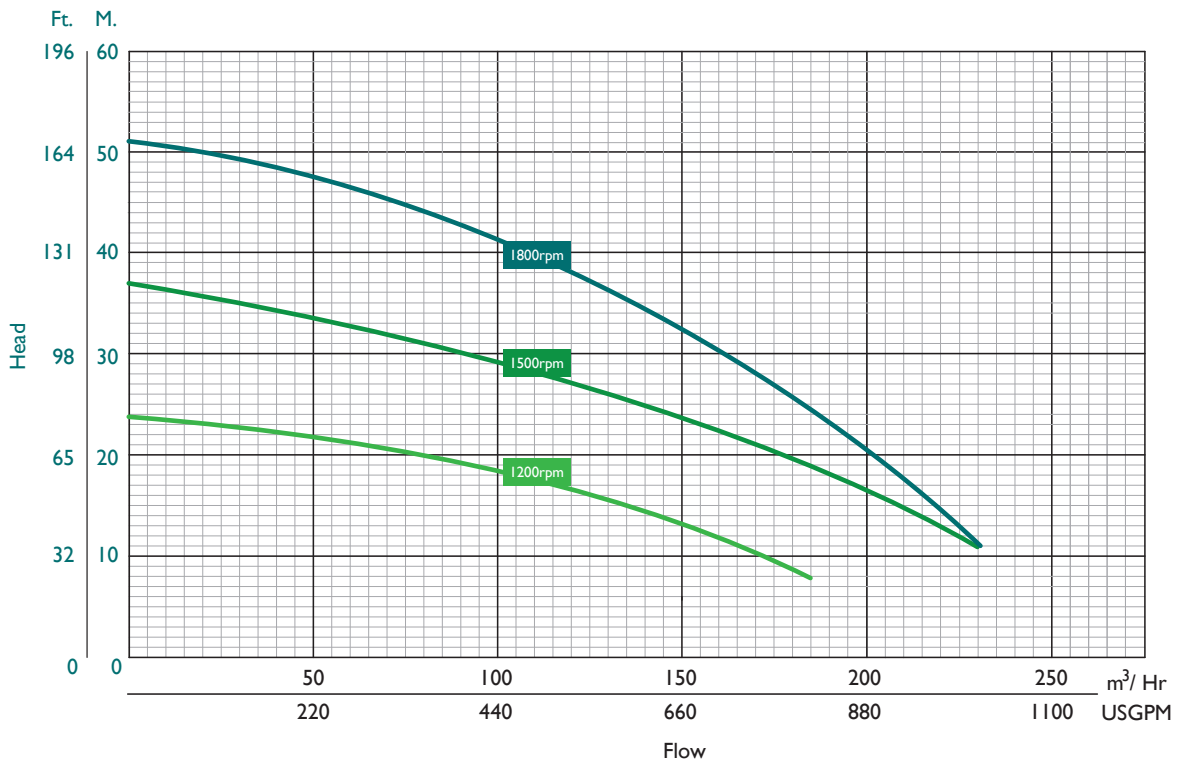

EXCAVATOR PUMPS**100 XP**
SlurryChamp

100mm heavy duty pump with a replaceable casing and drainless motor suitable for use as an excavator attachment. For use with an excavator rated at 10-25t.

**200 XP**
SlurryChamp

200mm heavy duty pump with a replaceable casing and drainless motor suitable for use as an excavator attachment. For use with an excavator rated at 25-40t.

**100 XPL**
SlurryChamp

100mm pump for light duty with a drainless motor suitable for use as an excavator attachment. For use with an excavator rated at 10-25t.

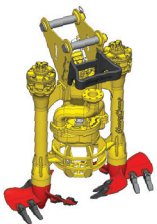
**100 XPSC**
SlurryChamp

100mm heavy duty pump with a replaceable casing and side cutters, suitable for use as an excavator attachment. For pumping heavily settled solids. For use with an excavator rated at 15-30t.

HOIST PUMPS**100**
SlurryChamp

100mm heavy duty pump with a replaceable casing suitable for use in a traditional suspended installation.

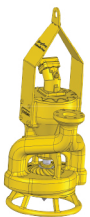
**100 L**
SlurryChamp

100mm light duty pump suitable for use in a traditional suspended installation.

**200**
SlurryChamp

200mm heavy duty pump with a replaceable casing suitable for use in a traditional suspended installation.